

INTERLOCK STITCH

High speed interlock stitch machine

C007 L - W 12 2 - 3 56 / CQ

②系列 Series

- L 高速型
Ultra High Speed
- LX 微油型
Semi-Dry
- KP K型進階款
K Plus
- K 基本款
Basic Type
- KD 基本款配直驅馬達
K Type with DD Motor

④功能 Function

- 12 一般平縫
General Plain Seaming
- 13 拷下擺
Bottom Hemming
- 15 羅紋褲頭鬆緊帶包縫
Tubular Rib-Fabric Elastic Waistband Attaching
- 16 一般厚布料之平縫
General Plain Seaming for Heavy Material
- 22 滾邊車縫
Tape Binding
- 32 拷克骨車縫
Overlock-Seam Covering
- 51 鬆緊帶上帶車縫
Elastic Tape Attaching
- 52 鬆緊帶附右切刀
Elastic Tape Attaching with Right Side Fabric Trimmer
- 53 環型鬆緊帶車縫
Tubular Elastic Waistband Attaching
- 54 鬆緊帶折縫
Elastic Hemming
- 61 褲耳車縫
Belt Loop Seaming
- 71 雙勾針結構
Double-Looper Mechanism
- 72 三勾針結構
Triple-Looper Mechanism
- 81 左切刀修布裝置
Left Side Fabric Trimming
- 82 鬆緊帶上帶邊縫附左切刀
Elastic Tape Insertion with Left Side Fabric Trimmer
- 92 四針六線搭接縫
Four-Needle Flat Seaming

⑥針數 Needle Numbers

Needle Numbers

⑧配件 Device

Device

⑦	No.	mm	inch
	32	3.2	1/8
	40	4.0	5/32
	48	4.8	3/16
	56	5.6	7/32
	64	6.4	1/4

⑤針板舌片 Needle Plate Finger

Needle Plate Finger

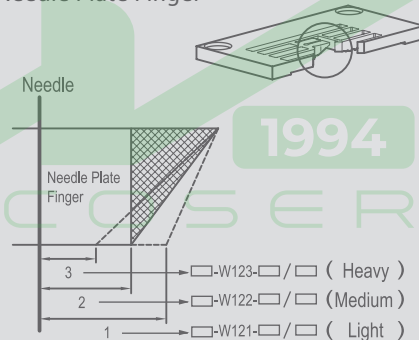

- 1 = 薄布料/細結線(密針)
Light Material/Short Stitch Length
- 2 = 中厚布料/中結線(一般針)
Medium Material/Common Stitch Length
- 3 = 厚布料/粗結線(粗針)
Heavy Material/Long Stitch Length

①機種別 Model

- C 筒型
Cylinder Bed
- F 平台型
Flat Bed
- S 小筒型
Small Cylinder Bed
- U 超小筒
Ultra Small Cylinder Bed

③網線方式 Covering Types

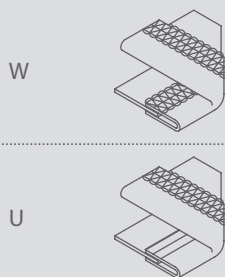

- ⑨DCL □□ C007L/LX 型直驅電控組
Direct-Drive Servo Motor for C007L/LX
- ⑨DCK □□ C007KP 型直驅電控組
Direct-Drive Servo Motor for C007KP
- ⑨DFK □□ F007KD 型直驅電控組
Direct-Drive Servo Motor for F007KD
- ⑨DSK □□ S007KD 型直驅電控組
Direct-Drive Servo Motor for S007KD
- ⑨DUK □□ U007 型直驅電控組
Direct-Drive Servo Motor for U007

INTERLOCK DD SERVO MOTOR

C007KP-W162-364 / CH / DCK □□

*馬達介紹, 詳細請參考P.114
Direct-direct, please refer to P.114

規格

SPECIFICATIONS

C007KP_W81 2 A - 2 32/ CRL / DCKU

規格索引, 詳細請參考P.65 Specification index, please refer to P.65

- ① 機種別 Mode
- ② 系列 Series
- ③ 網線方式 Covering Types
- ④ 功能 Function
- ⑤ 針板舌片 Needle Plate Finger
- ⑥ 針數 Needle Numbers
- ⑦ 針距 Needle gauge
- ⑧ 配件 Device
- ⑨ 馬達 Motor
U : U Series
H : H Series

C2 Device



C007KP-W812A-⑥⑦/CRL/(⑨)	2	4	3.2/ 4.0/ 4.8	1.4 ~ 3.6	0.3 ~ 2.9	5/7	H / U	4500
	3	5	5.6/ 6.4	1.4 ~ 3.6	0.3 ~ 2.9	5	H / U	4500



左切刀修布下擺車縫

附左切刀修齊布邊後, 再進行下擺車縫工程, 適用於車縫T恤、汗衫之下擺等

BOTTOM HEMMING WITH LEFT SIDE FABRIC TRIMMER

Left hand side fabric trimming before hemming. For sleeve opening and bottom of underwears, T-shirt, or sportswears, etc...

適用規格
APPLICABLE SPEC.

W812, U812

* 薄布料建議選購 W812
Recommended for thin fabrics

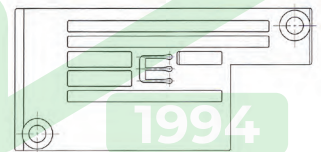

選購配件 OPTIONAL DEVICE

UTP, UTQ, UTR, CL, CMR, CAR/UTP, CAR/UTQ

C007KP-W812-356/
CRL

C3 Device



C007KP-W222-⑥⑦/CQ/(⑨)	2	4	4.0/ 4.8	1.4 ~ 3.6	0.3 ~ 2.9	5/7	H / U	6000
	3	5	5.6/ 6.4	1.4 ~ 3.6	0.3 ~ 2.9	5/7	H / U	6000
C007KP-W222-⑥⑦/CQA/(⑨)	3	5	5.6	1.4 ~ 3.6	0.3 ~ 2.9	5/7	H / U	5000



CQ:上帶滾邊車縫

適用於內衣褲、T恤之領口、褲管口等上帶滾邊之車縫工程

註: 滾邊器尺寸為入布端寬1-3/8" · 出布時折成三折 · 出口端成品寬為1/2"

CQ:TAPE BINDING

For tape binding on openings of leg or neck of underwears, T-shirts, etc...

Remark: Binder's opening size is 1-3/8" wide and finished size is 1/2" wide in three folds.

C007KP-W222-356/CQ

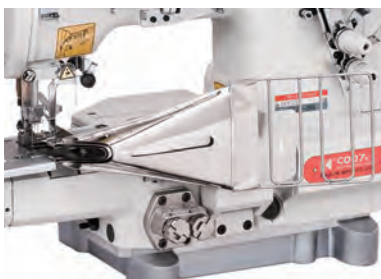

CQA:中厚毯上帶滾邊車縫

適用於中厚毯上帶滾邊之車縫工程

註: 滾邊器尺寸為入布端寬72mm · 出布時折成二折 · 出口端成品寬為36mm

CQA:BLANKET CARPET TAPE BINDING

For medium and heavy material tape binding.

Remark: Binder's opening size is 72mm wide and finished size is 36mm wide in two folds.

選購配件 OPTIONAL DEVICE

CLA, FA

C007KP-W222-356/CQA

規格 SPECIFICATIONS C007KP-W822-2 40/CRL/CHP/UTP/DCKU

規格索引, 詳細請參考P.65 Specification index, please refer to P.65

- ① 機種別 Mode
 - ② 系列 Series
 - ③ 網線方式 Covering Types
 - ④ 功能 Function
 - ⑤ 針板舌片 Needle Plate Finger
 - ⑥ 針數 Needle Numbers
 - ⑦ 針距 Needle gauge
 - ⑧ 配件 Device
 - ⑨ 馬達 Motor
U : U Series
H : H Series
- *UTP 請參考 Please refer to P.113

C8 Device

C007KP-W822-⑥⑦/CRL/CHP(CY)/UTP/(⑨)	2	4	3.2/ 4.0/ 4.8	1.4 ~ 3.6	0.3 ~ 2.9	5	H / U	4500
	3	5	5.6/ 6.4	1.4 ~ 3.6	0.3 ~ 2.9	5	H / U	4500

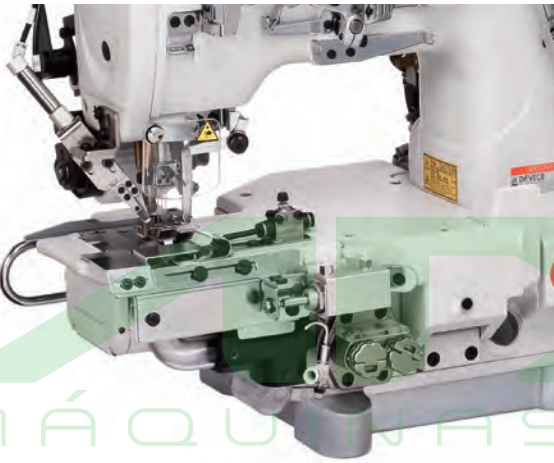

C007KP-W822-356/CRL/CL/CHP/UTP

[二合一]氣動式下擺車縫 / 環型鬆緊帶折縫
 附左切刀修布邊功能

氣動式布料導邊器能將布料及鬆緊帶順暢的捲折，此外左切刀切齊後再進行縫紉，可增加包縫工程之品質與效率，適用於男內褲、運動褲等褲頭鬆緊帶包縫

[2 IN 1]
 PNEUMATIC HEMMING / TUBULAR ELASTIC TAPE HEMMING WITH LEFT EDGE TRIMMER

With pneumatic driving folder to fold fabric and insert elastic smoothly, left hand side fabric trimming before hemming increases sewing quality & efficiency. For hemming sleeve opening and bottom of underwears, T-shirts, or sportswears, etc...

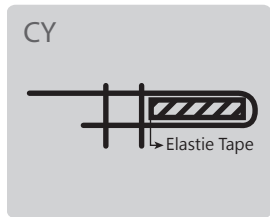
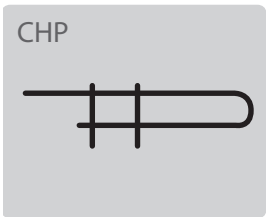
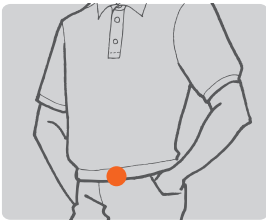

CHP (CRL 163)
 氣動式下擺車縫
 Pneumatic Hemming



CY (CRL178-A)
 氣動式環型鬆緊帶折縫
 Pneumatic Tubular Elastic Tape Hemming

適用規格 APPLICABLE SPEC
W821, W822, W823, U821, U822, U823
選購配件 OPTIONAL DEVICE
CL*, RL, UTQ, CMR, CAR/UTQ

*建議採用CL後拉輪，以提升鬆緊帶車縫效率
 *CL rear puller is recommended for elastic band attaching

